

External Blind System

Product Information

The Verosol **External Blind system** is manufactured from the highest quality materials that includes stainless steel, glass-filled nylon and extruded aluminium. These materials are complimented with high-performance external fabrics for controlling natural light, heat and solar energy.

Additionally, the External blinds has many unique features to simplify installation, improve reliability and provide the performance necessary to function for years to come. Placing high importance on aesthetics, slim and compact fittings are designed to integrate sleekly with any style of architecture.

Capable of wide spans, long drops, and having interchangeable components, makes Verosol External Blinds the perfect customised solution for outdoor comfort shading.

Further Information

To find out more information phone Verosol Customer Care on 1800 721 404 or visit www.verosol.com.au

Technical Information



Product Code	X200.7			
Product Name	External Roller Blinds			
Operation	Guide Wires		Verolock Side Channels	
Dimensions	Width	800mm min - 6500mm max	Width	800mm min - 6500mm max
	Drop	6000mm max	Drop	3600mm max
	Maximum Area	39m ²	Maximum Area	26m ²
Base Rail	Material	Extruded aluminium	1.7 kg/m	
	Dimensions	55mm W x 25mm H		
	Colours	White, Black, Silver Anodised		
Base rail end caps	Material	Stainless steel magnetic	Glass filled nylon	
	Colour	Black		
Guide Wires	Material	Stainless steel cable	N/A	
	Type	Masonry, Deck, Face		
Verolock Side Channel	Material	N/A	Verolock technology	
	Type		Zipper	
	Colour		White, Black, Silver Anodised	
Installation Brackets	Material	Premium stainless steel		
	Operation	Top or Face Fixing - concealed when installed		

Turn over for motorisation and optional extras

Motorisation

Product Code	X200.7		
Product Name	Verosol External Blind System		
Operation	Roller System		
	Head Box		No Head Box
Dimensions	Width	150 mm	120 mm
	Length	150 mm	120 mm
More Information	Refer to "8.0 Motorisation" in your Verosol Price List for more information		

Optional

Head Box System	Materials	End Caps: Cast Aluminium and Stainless Steel	
		Extrusion: Extruded Aluminium	
	Dimensions	150 mm x 150 mm	
	Colours	White, Black, Silver Anodised	
	Minimum Width	800 mm	
Side Channel		U-Channel	L-Channel
	Materials	Extruded Aluminium	Extruded Aluminium
	Dimensions	44.72 mm x 42 mm	40 mm x 40 mm x 16 mm
	Colours	White, Black, Silver Anodised	White, Black, Silver Anodised
	Maximum Length	3400 mm	3400 mm

System Diagrams

Guide Wires

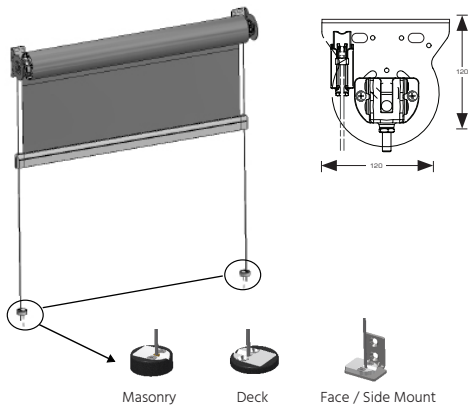

Head Box: Brackets

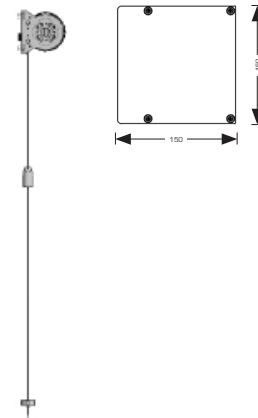

U-Channel

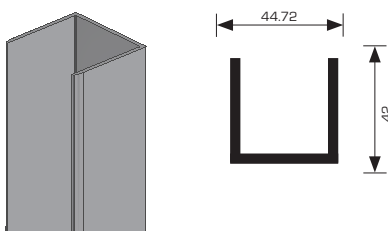

L-channel

