

Tali side table



The legs of this piece are the shape of the Timpilypa [music sticks].

Hand turned in solid spotted gum and left clear of the motif or totem. Lulu Cooley's Tali [sand dune] hot-wire burnt pattern is laid horizontal on a ply panel, to be viewed from above through the cooling effect of the ash-grey glass.

Standard size; 520 diameter x 470 (h)

Solid Spotted Gum frame clear finish

Hand turned Solid Spotted Gum Legs clear finish

10mm Ply panel with hand burnt Punu motif - Linseed oil finish

10mm Grey tinted Glass

NAME

Tali side table

MANUFACTURER

Altone

WARRANTY

10 years structural

Tali coffee table

SPECS

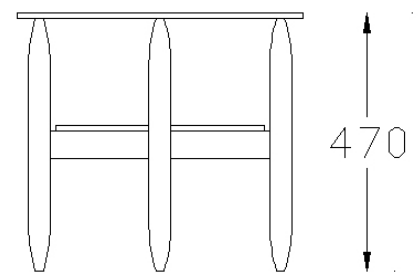
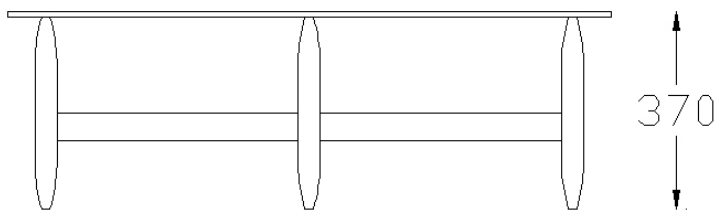
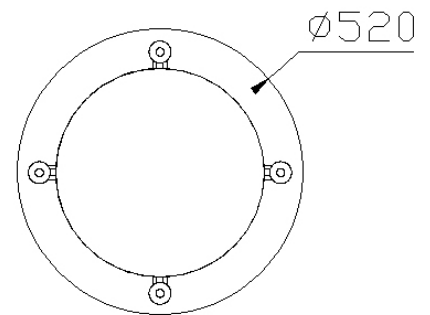
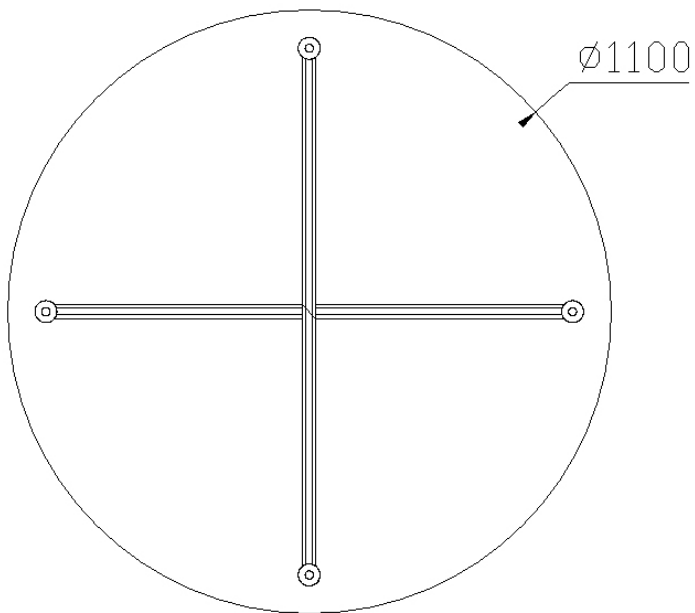

SYDNEY

269 Military Road, Cremorne 2090
02 9908 2660

MELBOURNE

681 Chapel Street, South Yarra 3141
03 9826 8777

FANULI
SYDNEY MELBOURNE EST 1976