



Solid wood and blockboard highboard with a wooden frame. Shelves and drawers assembled with traditional dovetail joints inside, with a grooved handle. The unique processing technique applied to the doors and the front of the drawers creates a sculptural effect through the extroflexion of the wood, endowing it with a sinuous movement.

STANDARD COMPOSITION: DOORS - 2 FIXED SHELVES - 2 ADJUSTABLE SMALL SHELVES - 5 INTERNAL DRAWERS
ADDITIONAL ACCESSORIES: SEE INTRODUCTION

CODE	SIZE	STRUCTURE	FRONTS	
			A1	A2
MOVE HIGH	W.114 x D.50 x H.150	WALNUT WITH AND WITHOUT KNOTS	■	■
		OAK WITH AND WITHOUT KNOTS	■	■
		PIGMENTED OAK WITH AND WITHOUT KNOTS	■	■

AVAILABLE FINISHES

A1: walnut without knots, walnut with knots
A2: oak without knots, oak with knots, cherry

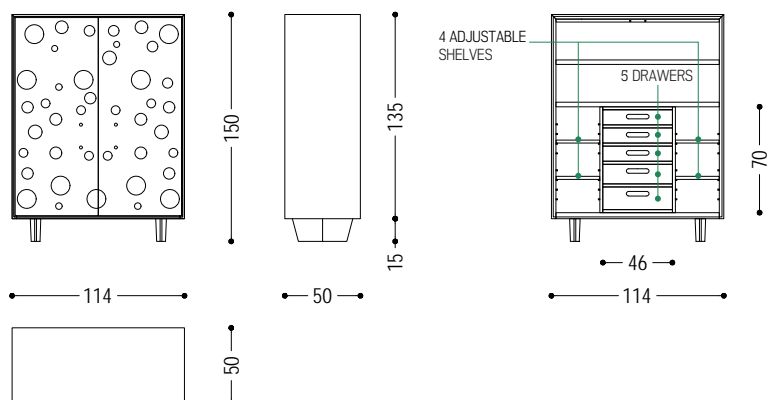

WOOD

A1

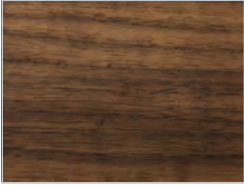

walnut without knots



walnut with knots

A2

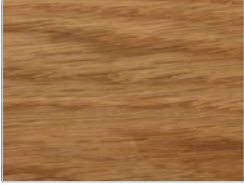

oak without knots



oak with knots

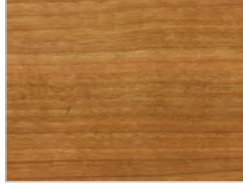

cherry