



Table featuring a top made of edge-glued solid wood staves, distinguished by a soft, sinuous organic outline inspired by the oval shape and finished with beveled edges. The base consists of two sculptural legs with a curvilinear, multi-lobed profile and a metallic-effect finish.

CODE	SIZE	BASE	A1	A2	A4
PAPILIO 1	W.220 x D.120 x H.73,5	B5	■	■	■
PAPILIO 2	W.240 x D.120 x H.73,5	B5	■	■	■
PAPILIO 3	W.260 x D.120 x H.73,5	B5	■	■	■
PAPILIO 4	W.280 x D.120 x H.73,5	B5	■	■	■

**AVAILABLE FINISHES**

**A1:** walnut without knots, walnut with knots

**A2:** oak without knots, oak with knots, cherry

**A4:** oak without knots pigmented: white milk, total black

**B5:** lacquered iron: bronze, cloudy effect

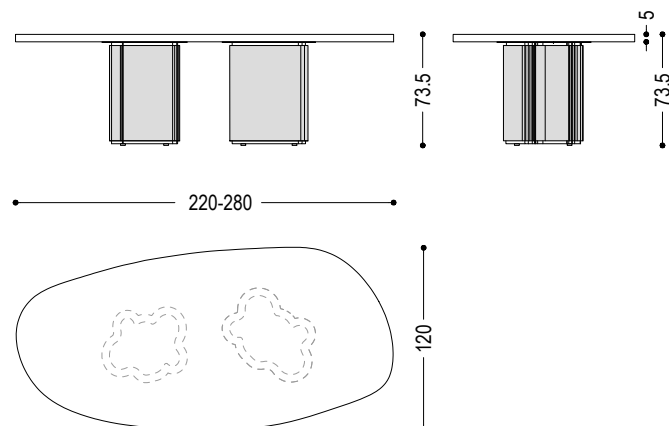

## WOOD

A1

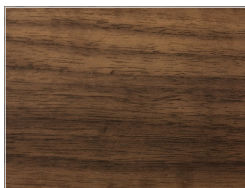

walnut without knots

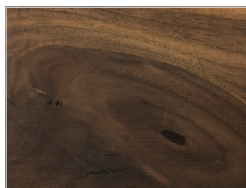

walnut with knots

A2

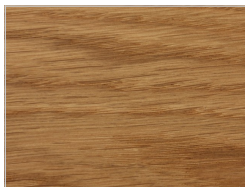

oak without knots



oak with knots

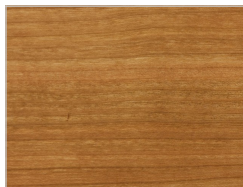

cherry

A4



oak without knots pigmented:  
white milk



oak without knots pigmented:  
total black

## IRON

B5



lacquered iron:  
bronze, cloudy effect