



Console featuring a top made of blockboard and solid wood, machined with a routed detail that defines a perimeter frame within which a marble slab is set. The base is composed of support elements arranged orthogonally, creating a clean, sculptural structure.

CODE	SIZE	TOP	A1	A2
SUISEKI-CON-MABLE1	W.140 x D.46,5 x H.80	F1	■	■
		F2	■	■
SUISEKI-CON-MABLE2	W.160 x D.46,5 x H.80	F1	■	■
		F2	■	■
SUISEKI-CON-MABLE3	W.180 x D.46,5 x H.80	F1	■	■
		F2	■	■

AVAILABLE FINISHES

A1: walnut without knots

A2: oak without knots, cherry

F1: verde alpi marble, carrara marble, emperador dark marble, sahara noir stoneware

F2: calacatta marble

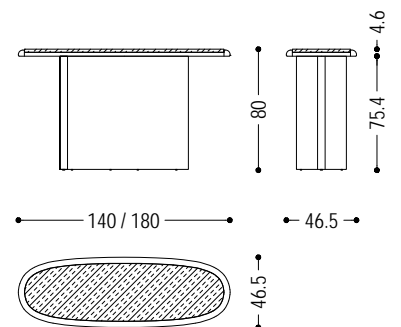



Solid wood console featuring a top machined with a routed detail that defines a perimeter frame and a slightly recessed central surface carved directly into the wood. The base is composed of support elements arranged orthogonally, giving the piece its clean, sculptural character.

CODE	SIZE	A1	A2
SUISEKI-COL-WOOD 1	W.140 x D.46,5 x H.80	■	■
SUISEKI-COL-WOOD 2	W.160 x D.46,5 x H.80	■	■
SUISEKI-COL-WOOD 3	W.180 x D.46,5 x H.80	■	■

AVAILABLE FINISHES

A1: walnut without knots

A2: oak without knots, cherry

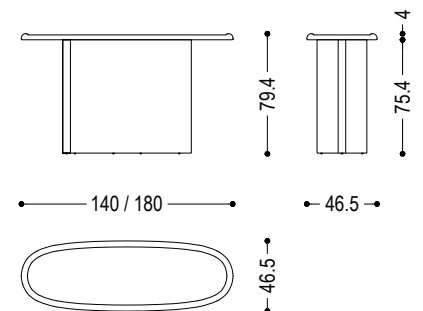

WOOD

A1



walnut without knots

A2



oak without knots



cherry

OTHER MATERIALS

F1



verde alpi marble



carrara marble



emperador dark marble

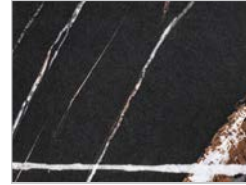

sahara noir stoneware

F2



calacatta marble